

DIGITAL PORTABLE 4.0/8.0 kW DRAGON LW SYSTEM WITH TOSHIBA FDX3543RP FLAT PANEL



Technical Specifications

DRAGON LW PORTABLE SYSTEM

is completely integrated and combines the high frequency x-ray generator's functions with the DR system's software, creating an efficient solution for portable x-ray requirements.

CONSISTING OF:

- Generator SPSLW-AL
- Portable Stand Dragon X Digital
- ImagePlus Software
- Toshiba FDX3543RP Flat Panel Detector



GENERATOR

- Console control integrated on the system with digital readout of kVp, mAs large/small focus selection, collimator light indicator and audible x-ray exposure signal
- Auto diagnostic system with error codes for easy maintenance
- kV selection from 40 to 125 (in 1 kVp steps)
- kVp Accuracy $\pm 3\% + 1\text{kV}$
- mA Range from 5 to 100 mA: 5, 6.4, 8, 10, 12.5, 16, 20, 25, 32, 40, 50, 64, 80, 100
- mAs, Automatic selection of the highest mA and shortest time based on tube limits.
- Range of mAs, from 0.1 - 250 mAs (in 25% steps)
- mAs Accuracy $\pm 5\% + 0.1 \text{ mAs}$
- Range of exposure times, from 0.001 to 10 seconds, automatic selection of the mAs. It can be shown in the display pressing simultaneously any bottom, for focus or mAs selection. (in 25% steps)
- ms Accuracy $\pm 2\% + 0.1 \text{ ms}$
- Manual collimator centering light indicator. SID measuring tape
- Power cord 19.7 ft (6 m.)
- X-Ray exposure cable 9.8 ft (3 m.)

Dragon 4.0kW

Maximum Power 4kW (@ 0.1s)

- 125 kVp @ 32 mA
- 100 kVp @ 40 mA
- 80 kVp @ 50 mA

Line Voltage 110/220 VAC, 50/60 Hz

Stationary Anode X-Ray Tube:

0.6-1.5mm focal spot

14° Anode Angle

40,000 HU Anode Heat Capacity

Total (tube & collimator) Inherent

Filtration: 2.9mm Al @ 75 kVp

Dragon 8.0kW

Maximum Power 8.0kW (@ 0.1s)

- 125 kVp @ 64 mA
- 100 kVp @ 80 mA
- 80 kVp @ 100 mA

Line Voltage 220 VAC 50/60 Hz

Stationary Anode X-Ray Tube:

0.6-2.8mm focal spot

14° Anode Angle

76,000 Anode Heat Capacity

Total (tube & collimator) Inherent

Filtration 2.9mm Al @ 75kVp

Line Power Detection System

A means to check the incoming power is provided. Once the available power has been determined, the exposure parameters are modified to accommodate the available power.

Generator Control Panel Display

- All controls and displays on the Control Panel are positioned according to their function
 1. Radiographic Displays
 2. RAD parameters
 3. Collimator Light
 4. Workstations
 5. Focal Spots
 6. Reset
 7. Exposure Controls

Dragon X Digital Portable Stand

- Mechanical locks for the rear wheels.
- The front swivel wheels and the back main wheels provide for comfortable ease of movement and positioning of the unit
- The arm is fully counterbalanced
- Arm flexibility:
 - o Vertical movement to lower or raise is controlled by gas shock absorber
 - o 360° rotation of the tube head
 - o 360° rotation of the tube head with reference to its stand (360° that can be limited by the SID guard and harness).
 - o 90° rotation of the collimator with reference to the tube head, with detent every 90°
- Maximum focus to floor 78.74" (200 cm)
- Minimum focus to floor 17.52" (44.5 cm)
- Maximum dimensions of the system: 87.7 x 26.4 x 65.4" (222.8 x 67 x 166 cm)
- Minimum dimensions of the system: 55.5 x 26.4 x 28.2" (141 x 67 x 71.5 cm)
- Weight 170 lbs (77.5 kg with detector & accessories)

ImagePlus+

ACQUISITION SOFTWARE:

The **ImagePlus+** digital software controls the x-ray generator, providing a smooth and time saving workflow. The professional DROC image processing can be adapted to individual user needs and provides complete control of all image capture functions within the examination room, enhancing the workflow by delivering diagnostic images instantly, and allowing users to move x-ray images electronically to remote workstations, image archives, and printers. Many helpful integrated functions such as intuitive operation simplifies the daily routine tasks.

In addition, the acquisition software provides

- Generator synchronization
- Image processing
- Image management (PACS, HIS/RIS etc.)
- DICOM Communication, full DICOM 3.0 Compatibility
- DICOM worklist from HIS/RIS store images through PACS network system
- DICOM image print
- DICOM MPPS

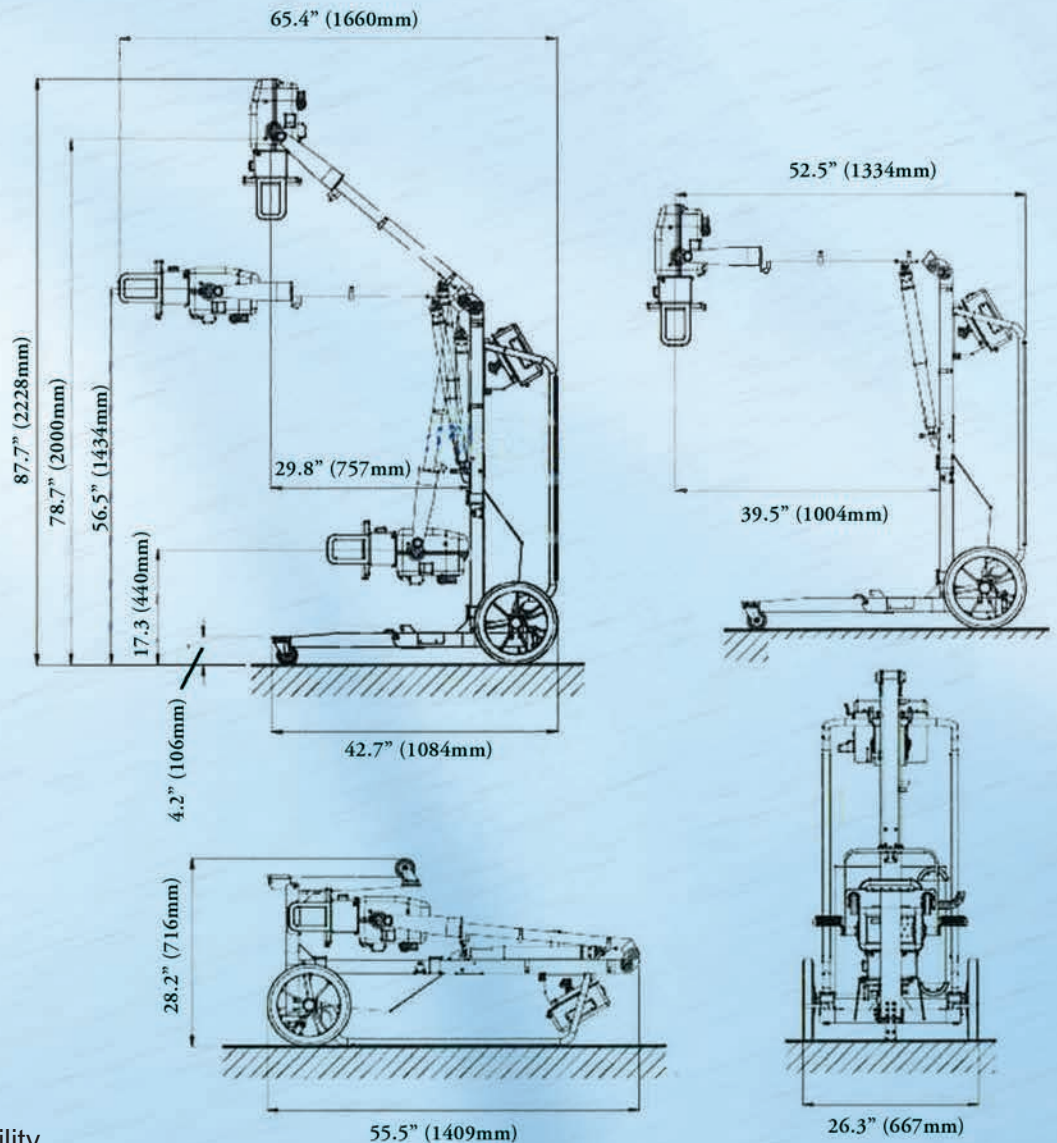

User Friendly and Smooth Workflow

- User interface adaptable to almost any language
- Touch screen operation providing quick and efficient workflow with 17" console. Touch screen panel with 1280x1024 resolution & true color
- Capture of patient data via DICOM worklist
- Use of DICOM Procedure Codes for the transfer of all relevant examination data directly from the available patient management system (HIS/RIS)
- Safe and fast registration of emergency patients
- Fully integrated radiographic positioning guide for each examination
- Exam specific algorithms image processing
- Automatic image optimization
- Reduces patient waiting time
- Instantaneous acquisition and processing of images
- Advanced noise reduction technology
- Optimized image calibration technology & minimized radiation dose

Remote Register:

- Support link with RIS/HIS of different providers and obtaining DICOM Worklist by configuring DROC

Register & Input:

- Local register: technician can input patient data, select relevant Exam/Study/Procedure items
- Edit existing patient information: Search patient by patient name, patient ID, accession number, barcode etc.
- Archive server /QA workstation (support auto routing, sending image to multiple nodes at the same time)

Output

- Printer (support auto routing, sending image to multiple nodes at the same time).
- Conventional mode, tube warm-up capability
- Programmed default exposure technique, which can be edited for every view

Exposure

- Exposure techniques for small/medium/large body size selection;
- Preview image within 6 seconds after exposure.
- Generator control integrated to the touch screen monitor

Patient Data Operation

- Search patient from local or modality worklist by barcode reader (if available). Detail search by PID, accession number and date. Register a patient; add an emergency examination.
- Setting of x-ray exposure parameters
- Operator-programmable settings for different views. Settings can also be manually adjusted.
- X-ray technique factors & exam-specific algorithms ensure optimal processing & display of the acquired image.
- Bucky orientation
- Rotate display
- Display bucky orientation: landscape or portrait
- Detector information
- Display detector temperature
- Display detector status: busy or free
- Thumbnail
- Indicate patient examination position
- Multi-study patient
- List current patient's all studies
- Switch study by selecting list

Outputs

- Individual output devices or user-defined combinations of devices.
- Selection of film size and layout
- Print true size image
- Selection of multi-destination output

X-Ray Technique Display

- After AEC exposure, post x-ray technique displayed

Basic Image Operation:

- Count clockwise/clockwise rotate
- Horizontal/Vertical flip
- Add/Clear image mark
- Add image annotation
- Automatic control for proper size
- Magnification image size
- Image cropping

Advanced Image Processing

- Symphony image processing
- Exam specific algorithm image processing
- Default algorithm setting can be configured

Histogram Display

- Control and analyse image through histogram
- Adjust image's window width/ window lever

Image Management

- Choose examined patients images
- Restore image to PACS
- Reprint image, film size and layout can be defined
- Review image / DICOM information
- Preview image, process image.
- Edit image information

Flexible Image Acquisition

Wide Ranged Compatibility:

- The generator interface enables the user to control the x-ray generator delivering the technique settings directly from the touch screen monitor
- Excellent maintainability for remote online system diagnosis & remote online software upgrade
- Image quality control tools with pixel fixing tools
- Flexible configuration including language localization
- APR (Anatomical Programmed Radiography) allow the user to automatically adjust all X-ray options for each exposure with an option to subsequently edit the image manually
- Optional integration of dose area products meters (DAP). The readings are saved directly to the relevant image. (Feature available if DAP chamber is installed in the system)
- ESA method configurable for each view
- Default algorithm settings stored in XML file and can be configured by UI
- Up to three image marks and one comment supported in one view (can be done automatically according to configuration)
- Image cropping (can be done automatically according to configuration)
- Image mirror, rotate (can be done automatically according to configuration)
- Add image accept/reject comments
- True size for printing

Symphony Professional Image Processing Software

Symphony software, a new image processing technology, is advanced processing for special digital radiographic image in DICOM format.

Symphony™ processing improves image contrast, adjusts dynamic range, enhances the details and reduces the noise, to produce the highest quality images. It expands the visibility of low-contrast structures such as tissue and vessels, while maintaining and enhancing the visibility of high-contrast structures such as bone. By optimizing the presentation of radiographic data, Symphony™ improves diagnostic quality for the radiologist to read images and make proper diagnosis.

Furthermore, Symphony™ has the ability to load the proper parameters automatically according to the anatomical regions it recognizes from the image.



Symphony™ Virtue

- High image quality with rich information and natural, completed details, eliminating the dark edges which always exist, result from normal image process algorithm
- Sufficient parameters providing better image quality
- Parameter settings set up by different body parts are easy to use
- Parameter settings can be customized
- High processing speed enabling complete image process in a few seconds
- Optimize image processing parameters automatically for diagnosis
- Contrast equalization helps to display an image with complex structure
- Provide more information for diagnosis, such as better view for soft tissue and bone trabecula structure

FLAT PANEL DETECTOR TOSHIBA FDX3543RP

MAIN CHARACTERISTICS:

Image Format:

- X-ray Conversion Layer: Cesium Iodide (CsI) with Amorphous Silicon (a-Si) Photodiode
- Active Area: 350 (H) × 43 (V) mm (14 x 17")
- Pixel Matrix: 2.448 (H) × 2.984 (V)
- Pixel Pitch: 143 μm
- Cycle Time: Shot to Shot 6 sec.

Performance:

- Limiting Resolution: 3.7 lp/mm typ.
- MTF (2.0 lp/mm, 70 kVp, 1x1): 36% Typ.
- DQE (0), Quantum - Limited: > 70%
- A/D Conversion: 16 bit

Ratings:

- Energy Range: 40 - 150 kVp
- Maximum Entrance Dose (low Gain): 4 mR / frame

Interface:

- Data Output: 16 bit Digital Output Ethernet (1000BASE-T)
- Command Control: Ethernet (1000BASE-T)
- X-ray Synchronization Control: External
- Power Input: DC 24V 2A (from Power Supply Unit (Option))

Image Acquisition Mode Table:

- Mode: 3072 lines Full Scan mode
- Frame rate (Frame/s): 1(approx)
- Binning/non-Binning: Non-binning

COMPONENTS AND CHARACTERISTICS:

Flat Panel Sensor Unit:

- Sensor Protection Plate: Carbon Fiber Plate
- Cooling: Natural Air Cooling
- Input: DC 15V (from AC/DC Power Supply)
- Power Consumption: Maximum 20W
- Overall Dimensions: 384 x 460 x 15 mm (15.12" x 18.11" x 0.59")
- Weight: 3kg (6.6 lbs)

Power Supply Unit:

- Input: AC 100 to 240V, 50/60Hz Output: DC 24V 1.3A 60W
- Overall Dimensions: : 115 x 185 x 85 (4.53" x 7.28" x 3.35")
- Weight: 1 kg (approx.) (2.2 lbs)

Integration Generator

- Control Panel integration with the touch screen operator console. The radiographic parameters are automatically selected through the anatomical programmer “APR” and allowing the manual modification of the parameters.
- Programming or modification of the technique parameters via the “APR”.
- Display of the exposure parameters on screen, even dose parameters (if the system has the option), and storage with the DICOM image of demographic and exposure data.

Computer T7500

- Medical Grade PSU-ATX (180W)
- CPU: Intel Core2Duo - 2.2 GHz
- Operating System: Windows 7 64bits
- Memory: 4GB RAM, Dual Channel, DDRII 667MHz.
- WLAN 802.11b/g (VIA VNT6656)
- Hard disk drive: 320GB 2.5” SATA

Integrated Touch Screen Monitor 17”

- 17.0" diagonal Aspect Ratio 5:4
- Resolution 1280 x 1024
- Viewing Angle (typical)
 - o Horizontal: $\pm 80^\circ$ or 160° total
 - o Vertical: $\pm 80^\circ$ or 160°
- total Contrast Ratio (Typical) 1000:1

OPTIONS:

- 1) Wheels, Rear:
Standard: Rigid plastic wheels
Optional: Pneumatic Wheels
- 2) Front Leg:
Standard: "T" Shape
Optional: "Y" Shape to avoid main support in some military beds.
- 3) Lateral Movement Kit: This system allows easy and precise lateral positioning of the system.
- 4) Foldable front wheels: Wheels facilitate the movement of the unit when folded.
- 5) Aluminium transportation case with ramp and wheels:
- 6) Key to inhibit x-ray exposure by unauthorized personnel.
- 7) Inclinometers to indicate the angle of the x-ray assembly.
- 8) DVD RW assembly for Dragon DR.